

Original instructions

Pamir 3200

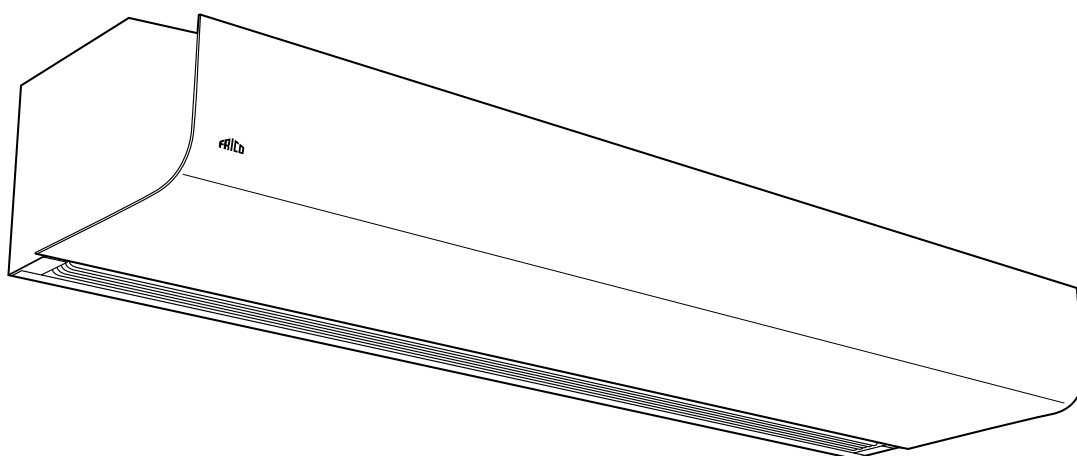

EN ...9

FR ...12

Pamir 3200

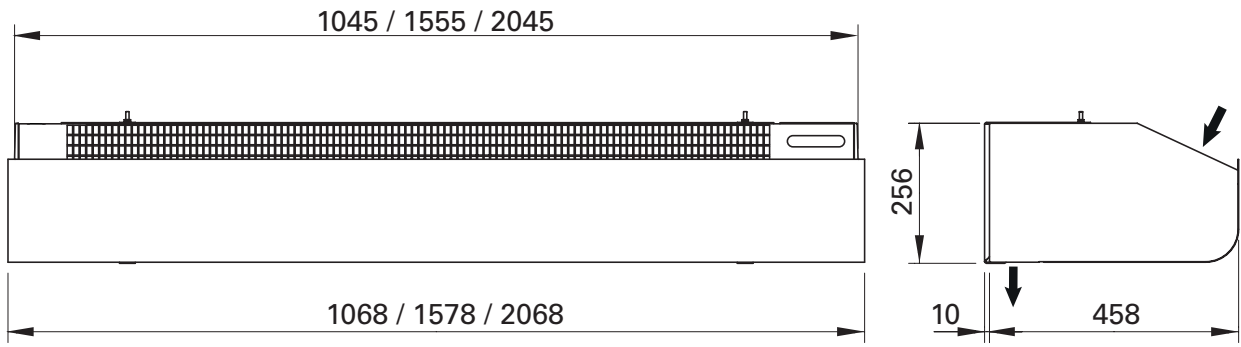

1 m / 1,5 m - PAF3210 / PAF3215

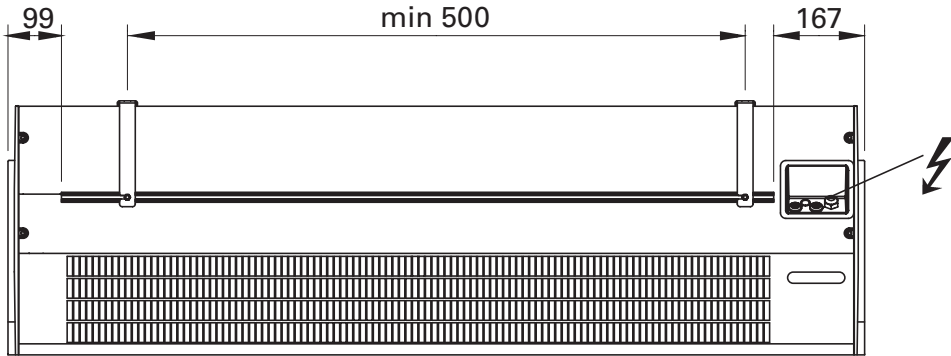

2 m - PAF3220

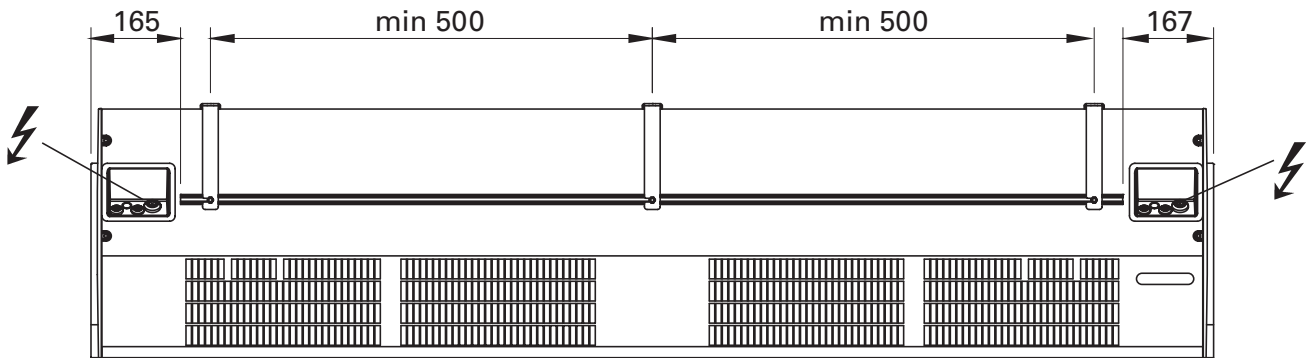

Minimum distances / Distances minimales

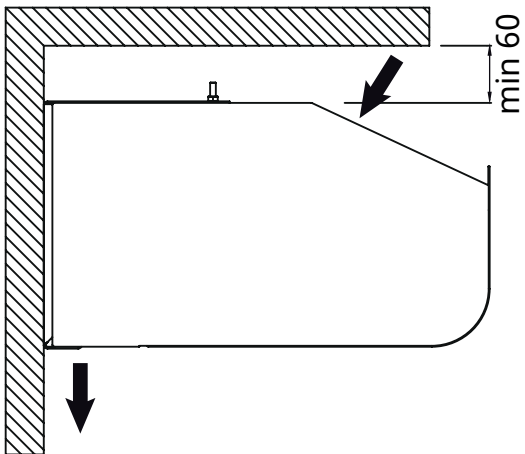

Fig. 1

Pamir 3200

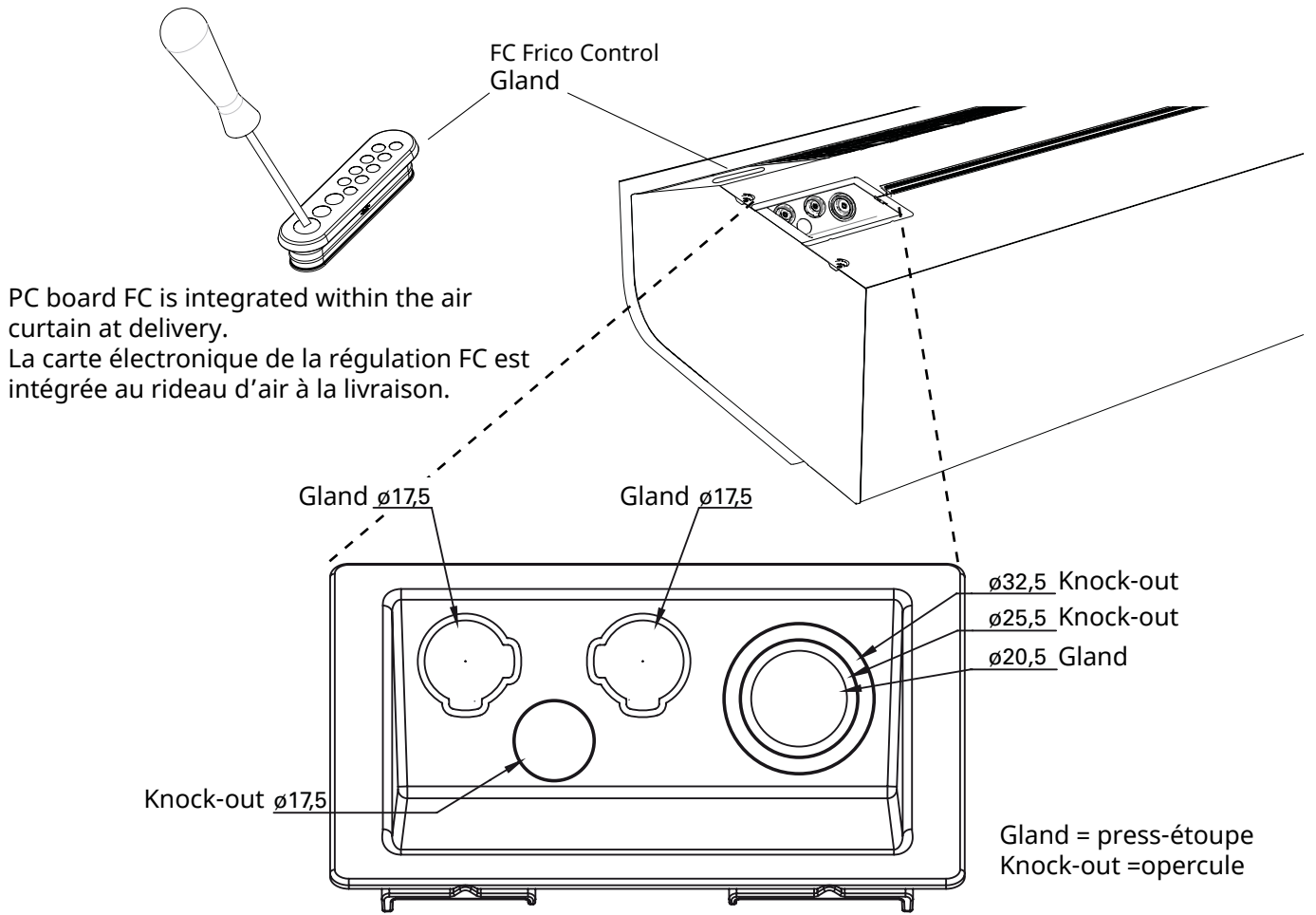

Fig. 2 Connections

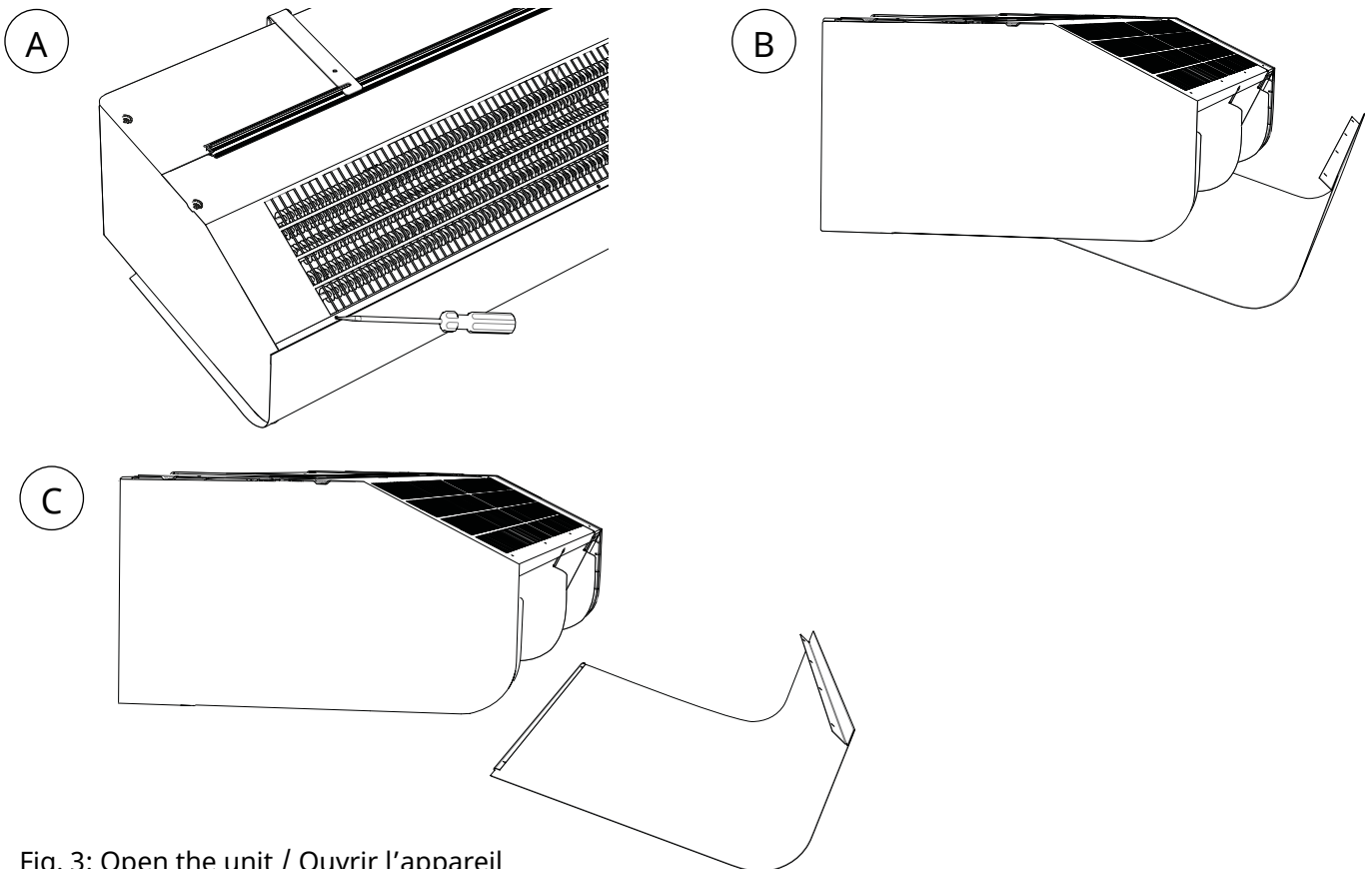

Fig. 3: Open the unit / Ouvrir l'appareil

Pamir 3200

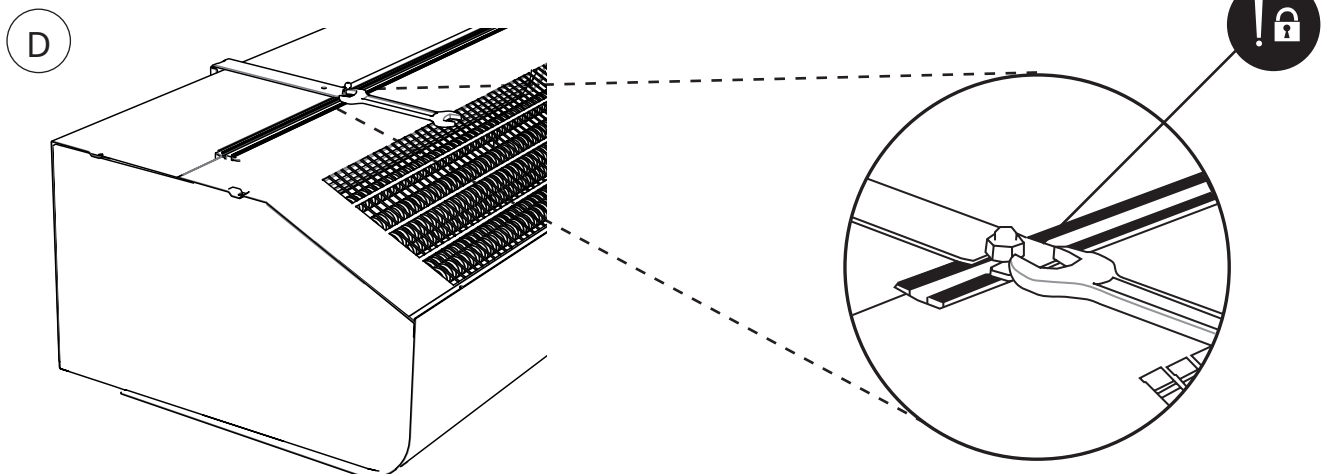
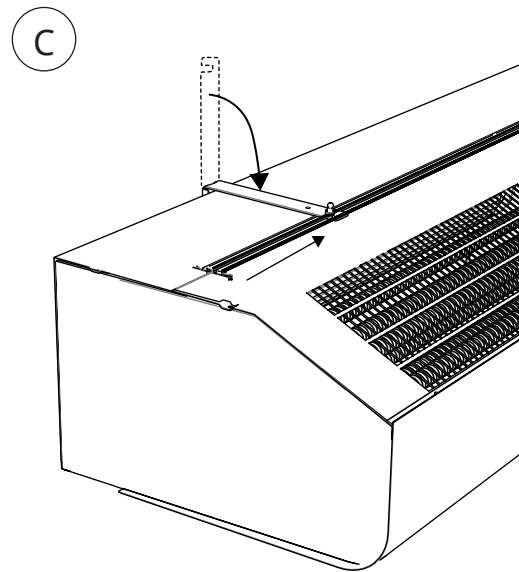
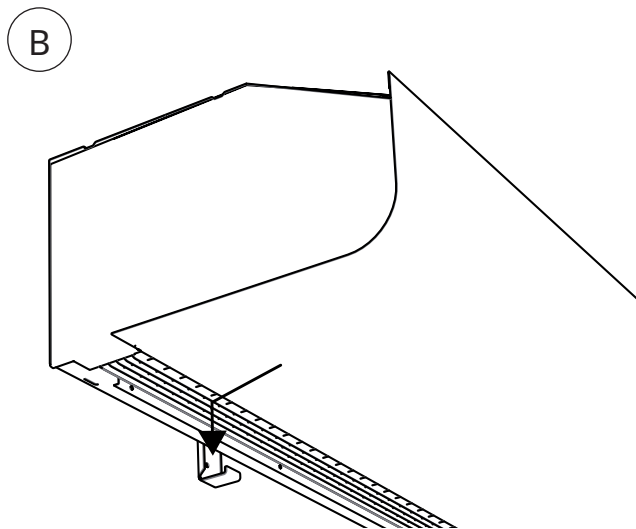
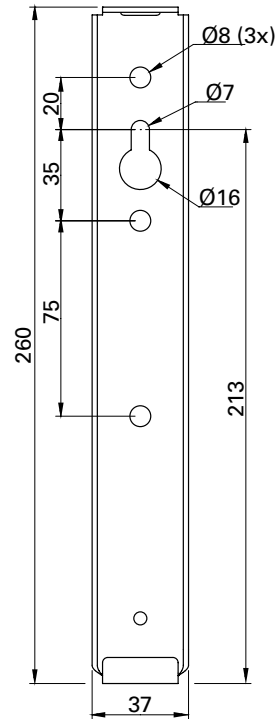
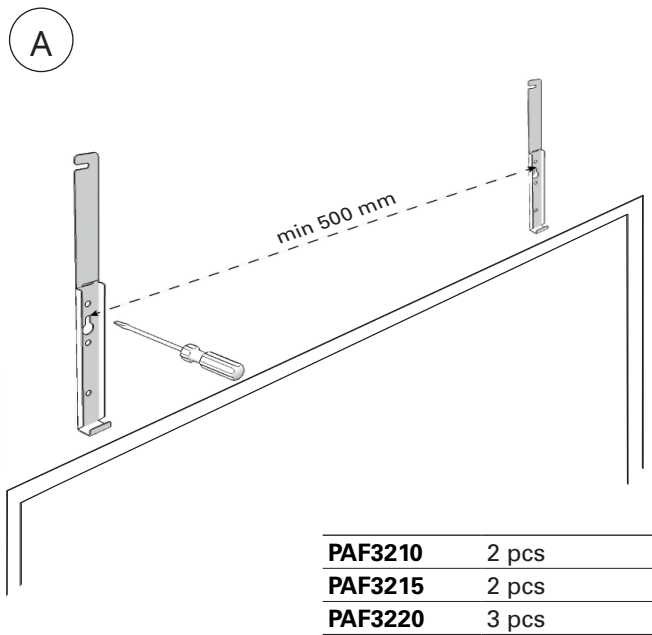
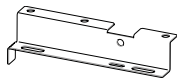

Fig. 4: Mounting with wall brackets / Installation avec des consoles pour montage mural

Pamir 3200

Accessories / Accssoires



PA3PF



PA34TR

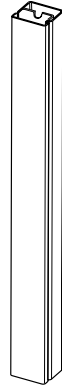

PA2P

Item number	Type	Used for	Consists of	Dimensions
25256	PA3PF15*	PAF3210/3215	4 pcs	
25257	PA3PF20*	PAF3220	6 pcs	
18056	PA34TR15*	PAF3210/3215	4 pcs	L: 1 m
18057	PA34TR20*	PAF3220	6 pcs	L: 1 m
19568	PA2P15*	PAF3210/3215	2 pcs	L: 1 m
19569	PA2P20*	PAF3220	3 pcs	L: 1 m

*) See separate manual. / Consultez la notice associée.

Control systems / Système de régulation

The air curtain must be supplemented with a control system.
Un système de régulation doit être intégré au rideau d'air.

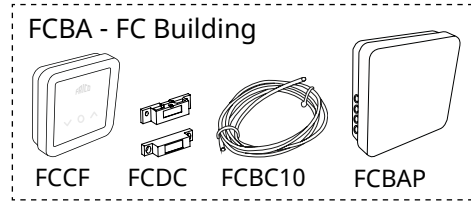
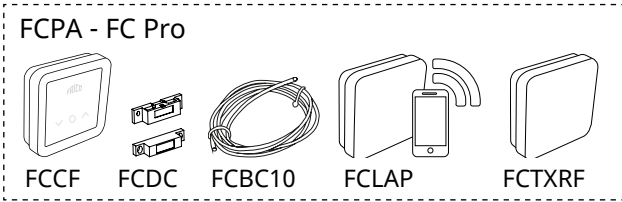
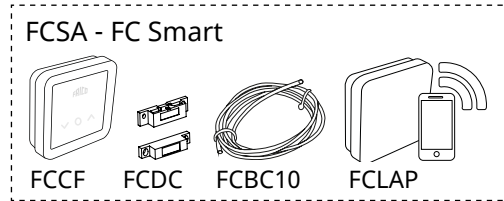
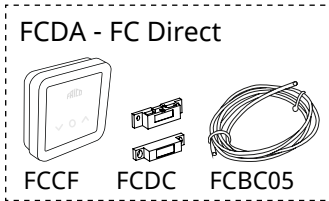

Item number	Type	Name	Dimensions
74684	FCDA	FC Direct	89x89x26 mm (FCCF)
74685	FCSA	FC Smart	89x89x26 mm (FCCF)
74686	FCPA	FC Pro	89x89x26 mm (FCCF)
74687	FCBA	FC Building	89x89x26 mm (FCCF)

Accessories / Accessoires

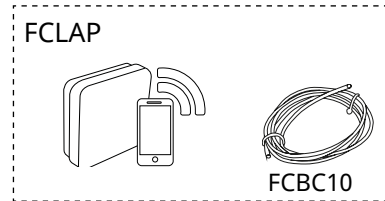
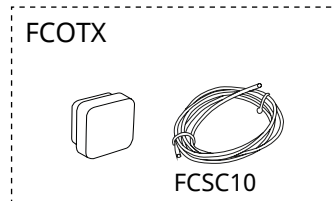
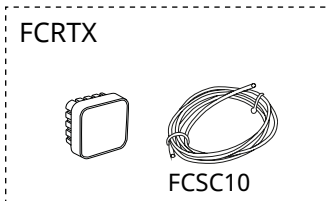

Item number	Type	Dimensions
74694	FCRTX	39x39x23 mm
74695	FCOTX	39x39x23 mm
74699	FCLAP	89x89x26 mm
17495	FCDC	
74718	FCBC05	5 m
74719	FCBC10	10 m
74720	FCBC25	25 m
74721	FCSC10	10 m
74722	FCSC25	25 m
74703	FCTXRF for FC Smart, FC Pro	89x89x26 mm

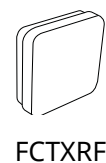
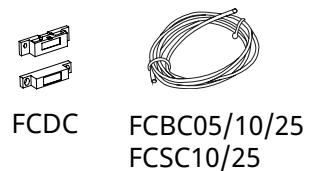

See separate manual for FC. / Consultez la notice de FC.

Technical specifications

Voltage motor: 230V~

⚡ Electrical heat / Chauffage électrique - Pamir 3200 E (IP20)

Item number	Type	Output steps [kW]	Airflow* ¹ [m ³ /h]	Δt * ⁴ [°C]	Sound power* ² [dB(A)]	Sound pressure* ³ [dB(A)]	Motor [W]	Amp. motor [A]	Voltage [V] Amperage [A] (heat)	Weight [kg]
251417	PAF3210E08	3/5/8	1100/1750	22/13	72	46/57	168	0,65	400V3N~/11,6	31
251418	PAF3215E12	3,9/8/12	1700/2750	21/13	75	46/59	283	1,0	400V3N~/17,3	42
251419	PAF3220E16	6/10/16	2300/3500	22/13	76	50/60	366	1,3	400V3N~/23,1	59

*¹) Lowest/highest airflow of totally 3 fan steps.

*²) Sound power (L_{WA}) measurements according to ISO 27327-2: 2014, Installation type E.

*³) Sound pressure (L_{pA}). Conditions: Distance to the unit 5 metres. Directional factor: 2. Equivalent absorption area: 200 m². At lowest/highest airflow.

*⁴) Δt = temperature rise of passing air at maximum heat output and lowest/highest airflow.



*¹) Débit d'air mini/maxi de 3 étages de ventilation au total.

*²) Mesures de la puissance acoustique (L_{WA}) selon la norme ISO 27327-2 : 2014, Installation de type E.

*³) Pression acoustique (L_{pA}). Conditions : Distance de l'appareil : 5 mètres. Facteur directionnel : 2. Surface d'absorption : 200 m². Au débit d'air minimal/maximal.

*⁴) Δt = augmentation de température sous un débit d'air mini / maxi et une puissance maximale.

Output steps [kW]	= Etages de puissance
Airflow* ¹ [m ³ /h]	= Débit d'air
Sound power* ² [dB(A)]	= Puissance acoustique
Sound pressure* ³ [dB(A)]	= Pression acoustique
Voltage motor [V]	= Tension moteur
Amperage motor [A]	= Intensité moteur
Voltage / Amperage heat	= Tension/Intensité chauffage
Weight [kg]	= Poids

PAF3200 E

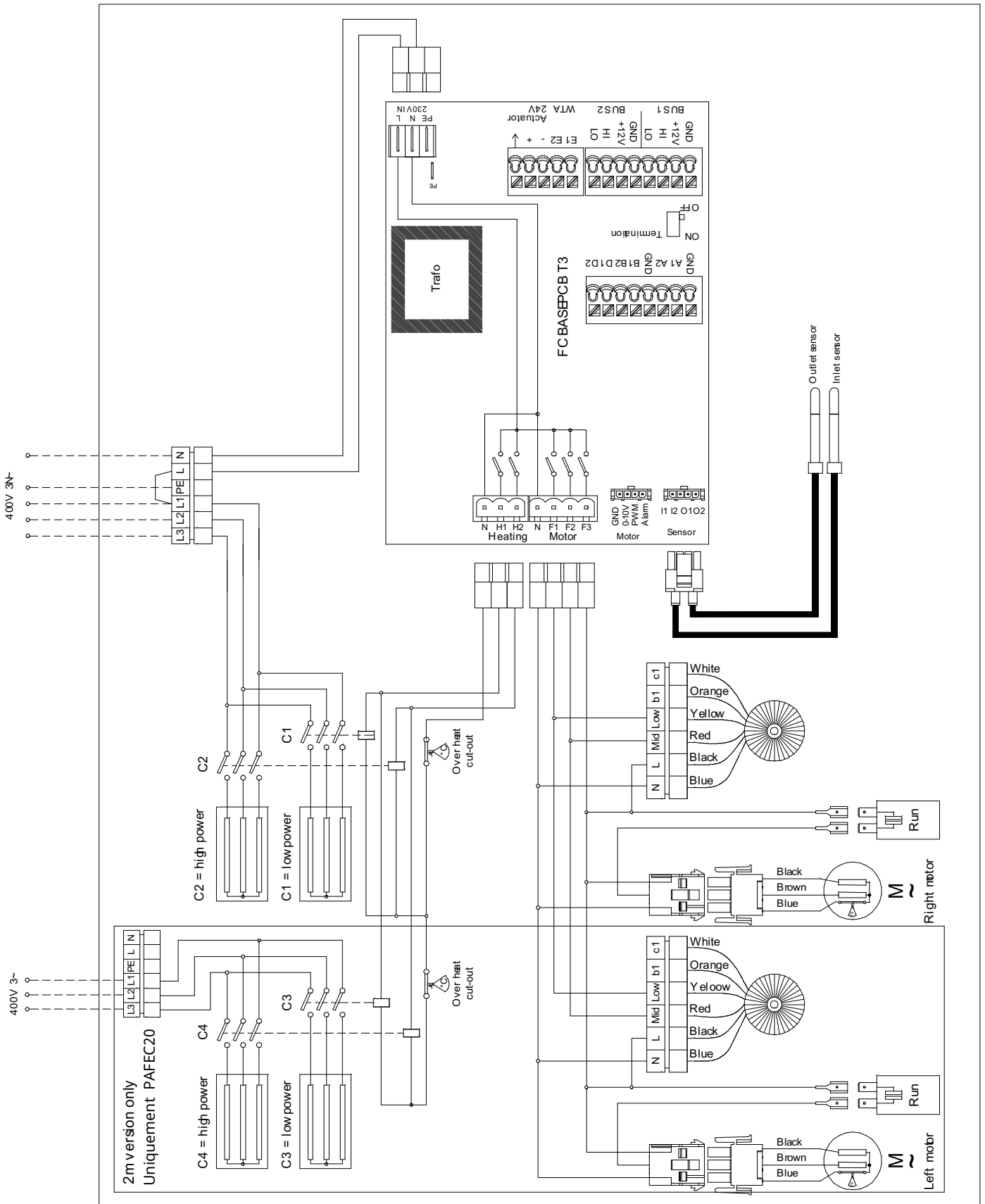

Wiring diagrams for control system in the FC manual.

Schémas de raccordement du système de régulation disponibles dans la notice du système FC.

Installation and operating instructions

General Instructions

Read these instructions carefully prior to installation and use. Keep this manual for future reference.

The product may only be used as set out in the assembly and operating instructions. The guarantee is only valid should the product be used in the manner intended and in accordance with the instructions.

Application

Pamir 3200 is an air curtain with electrical heating and a recommended installation height of 3,2 m. Protection class: IP20.

Operation

Air is drawn in at the top of the unit and blown downwards shielding the door opening and minimizing heat loss. To achieve the optimum curtain effect the unit must extend the full width of the door opening.

The grille for directing the outlet air is adjustable and is normally angled outwards to achieve the best protection against incoming air.

The efficiency of the air curtain depends on the air temperature, the pressure differential across the doorway and any wind load.

NOTE! Negative pressure in the building considerably reduces the efficiency of the air curtain. The ventilation should therefore be balanced.

Mounting

The air curtain is installed horizontally with the outlet air grille facing downwards as close to the door as possible. The product must be mounted in such a way to allow future service and maintenance. Minimum distance from outlet to floor for electrically heated units is 1800 mm. For other minimum distances, see fig. 1

Mounting with wall brackets (fig. 4)

1. Mount the brackets on the wall, see fig.4A and dimension drawing. If the wall is uneven the brackets must be compensated for this.
2. Hook on the unit at the lower edge of the brackets. (Fig.4B)
3. Bend the top of the console over the the unit and slide the units screws along the rail into the slots on the consoles. (Fig.4C) When the bracket is bent once, it must be replaced if

bent back more than 45 °.

4. Lock the nuts against the brackets. (Fig.4D)

Horizontal mounting on the ceiling

Threaded rods, hanging brackets and ceiling mounting brackets for ceiling mounting are available as accessories, see accessories pages and separate manuals.

Electrical installation

The installation, which should be preceded by an isolator switch with a contact separation of at least 3 mm, should only be wired by a competent electrician and in accordance with the latest edition of IEE wiring regulations.

The air curtain has an integrated PC board which is connected to the selected external control system FC. FC must be ordered separately. The PC board is accessed via cable glands on the top of the unit. See Fig. 2. FC is supplied pre-programmed. Communication- and sensor cables are connected to the PC board.

Should more than one air curtain be controlled by a single FC, an additional communication cable FCBC per unit will be required. See manual for FC.

The electrical connection is made on the top of the unit. Pierce the gland with a screwdriver before entering the cable. See Fig. 2. Control (230V~) and power supply for heat (400V3~) should be connected to a terminal block in the terminal box. 2-metre and longer units require dual power supplies. See dimension drawing and wiring diagram.

The largest cable diameter for the terminal block is 16 mm². The cable glands used must meet the protection class requirements. In the distribution board, it is to be indicated that "the air curtains can be supplied from more than one connection".

Type	Output [kW]	Voltage [V]	Minimum area* [mm ²]
Control	0	230V~	1,5
PAF3210E08	8	400V3~	2,5
PAF3215E12	12	400V3~	4
PAF3220E16* ¹	8	400V3~	2,5
	8	400V3~	2,5

*¹) 2 m units are connected with two power supplies.

*²) Dimensioning of external wiring shall comply with applicable regulations and local deviations may occur.

Start-up

When the unit is used for the first time or after a long period of non-use, smoke or an odour may result from dust or dirt which has collected on the element. This is completely normal and disappears after a short time.

Adjustment of the air curtain and airflow

The direction and speed of the airflow should be adjusted considering the load on the opening. Pressure forces affect the airstream and force it inwards towards the premises (when the premises are heated and the outdoor air is cold).

The airstream should, therefore, be directed outwards to withstand the load. Generally speaking, the higher the load, the greater the angle required.

Basic setting fan speed

The fan speed when the door is open is set using the control. Note that the airflow direction and the fan speed may need fine adjustment depending on the loading of the door.

Service, repairs and maintenance

For all service, repair and maintenance first carry out the following:

1. Disconnect the power supply.
2. The front hatch is removed by removing the screws on the top of the unit and then detach the bent edge at the bottom. (Fig.3)
3. After the service, repair and maintenance reattach the front hatch. Place the hatch at the lower edge with the bent edge and fasten on top with screws.

Note that when carrying out work where the end is removed, the outlet grille also detaches.

Maintenance

Since fan motors and other components are maintenance-free, no maintenance other than cleaning is necessary. The level of cleaning can vary depending on local conditions. Undertake cleaning at least twice a year. Inlet and exhaust grilles, impeller and elements can be vacuum cleaned or wiped using a damp cloth. Use a brush when vacuuming to prevent damaging sensitive parts. Avoid the use of strong alkaline or acidic cleaning agents.

Temperature control

Temperature control of FC maintains the exhaust temperature. Should the temperature exceed the preset value, the overheating alarm

will activate. For more information see the FC manual.

Overheating

The air curtain unit with electrical heating is equipped with an overheat protection. If it is deployed due to overheating, reset as follows:

1. Disconnect the power supply with the isolator switch.
2. Determine the cause of overheating and rectify the fault.
3. Remove the front hatch.
4. Press the red button located inside the air curtain unit, at the inner gable of the terminal box.
5. Reattach the front hatch and connect the unit again.

All motors are equipped with an integral thermal safety cut-out. This will operate, stopping the air curtain should the motor temperature rise too high. The cut-out will automatically reset when the motor temperature has returned to within the motor's operating limits.

Replacing heating elements/heating package (E)

1. Mark and disconnect the cables to the heating elements/package.
2. Remove the mounting screws securing the heating elements/package in the unit and lift the heating elements/package out.
3. Install the new heating elements/package in reverse order to the above.

Replacing motor or impeller

1. Remove the front.
2. Remove gable end.
3. Remove the screw between motor and fan.
4. Disconnect the cables to the motor.
5. Remove the screws securing the motor and lift it out together with the impeller.
6. Install the new motor and/or the new impeller as above in reverse order.

Replacing the PC board

1. The PC board is located in the terminal box. Fig. 2
2. Mark and disconnect the cables to the PC board.
3. Remove the screws securing the board and lift out.
4. Install the new PC board as above in reverse order.

Troubleshooting

If the fans are not running or do not perform properly, check the following:

- The power supply.
- That the intake grille/filter is not dirty.
- That the motor's safety cut-out has not been deployed.
- Functions and settings of the FC control system, see the FC manual.

If there is no heat, check the following:

- Functions and settings of the FC control system, see the FC manual.

For units with electrical heating, also check the following:

- Power supply to electric heater coil; check fuses and circuit-breaker (if any).
- That the overheat protection has not been deployed.

If the fault cannot be rectified, please contact a qualified service technician.

Residual current circuit breaker (E)

When the installation is protected by means of a residual current circuit breaker, which trips when the appliance is connected, this may be due to moisture in the heating element. When an appliance containing a heater element has not been used for a long period or stored in a damp environment, moisture can enter the element.

This should not be seen as a fault, but is simply rectified by connecting the appliance to the main supply via a socket without a safety cut-out so that the moisture can be eliminated from the element. The drying time can vary from a few hours to a few days. As a preventive measure, the unit should occasionally be run for a short time when it is not being used for extended periods of time.

Packaging

Packaging materials are chosen with consideration to the environment and are therefore recyclable.

Handling of product at end of working life

This product may contain substances necessary for the functionality of the product but potentially dangerous for the environment. The product should not be disposed of mixed with general household waste but delivered to a

designated collection point for environmental recycling. Please contact the local authority for further details of your nearest designated collection point.

Safety

- *For all installations of electrically heated products a residual current circuit breaker 300 mA for fire protection should be used.*
- *Keep the areas around the air intake and exhaust grilles free from possible obstructions!*
- *The unit must not be fully or partially covered as overheating can result in a fire risk!*
- *Lifting equipment must be used to lift the unit.*
- *This appliance can be used by children aged from 8 years and above and persons with reduced physical, sensory or mental capabilities or lack of experience and knowledge if they have been given supervision or instruction concerning use of the appliance in a safe way and understand the hazards involved. Children shall not play with the appliance. Cleaning and user maintenance shall not be made by children without supervision.*
- *Children of less than 3 years should be kept away unless continuously supervised.*
- *Children aged from 3 years and less than 8 years shall only switch on/off the appliance provided that it has been placed or installed in its intended normal operating position and they have been given supervision or instruction concerning use of the appliance in a safe way and understand the hazards involved.*
- *Children aged from 3 years and less than 8 years shall not plug in, regulate and clean the appliance or perform user maintenance.*

CAUTION — Some parts of this product can become very hot and cause burns. Particular attention has to be given where children and vulnerable people are present.



Main office

Frico AB

Industrivägen 41

SE-433 61 Sävedalen

Sweden

Tel: +46 31 336 86 00

mailbox@frico.se

www.frico.net

**For latest updated information and information
about your local contact: www.frico.net.**