

Original instructions

Arden 3200

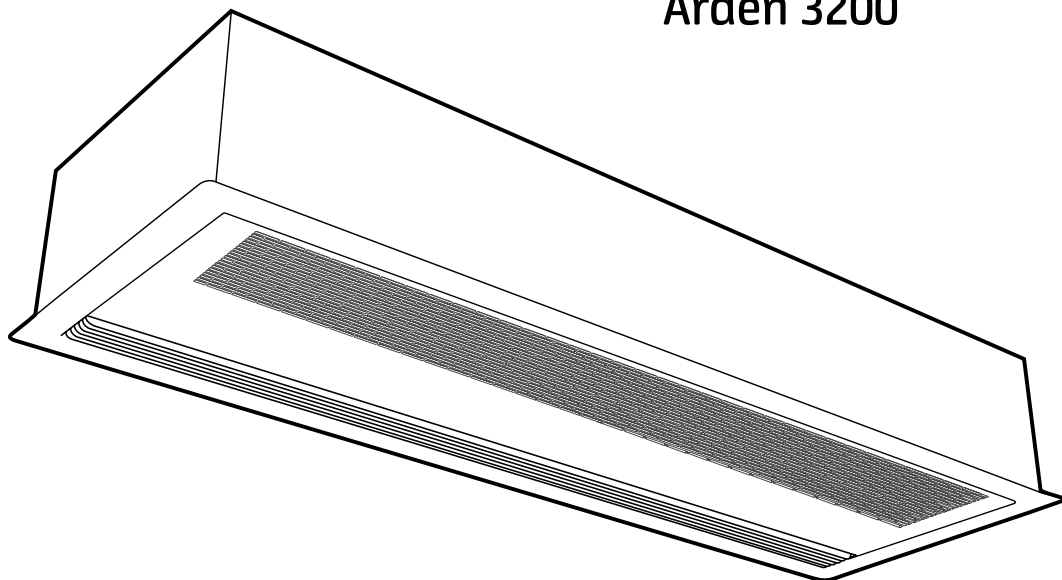

EN 14

FR ... 18

Arden 3200

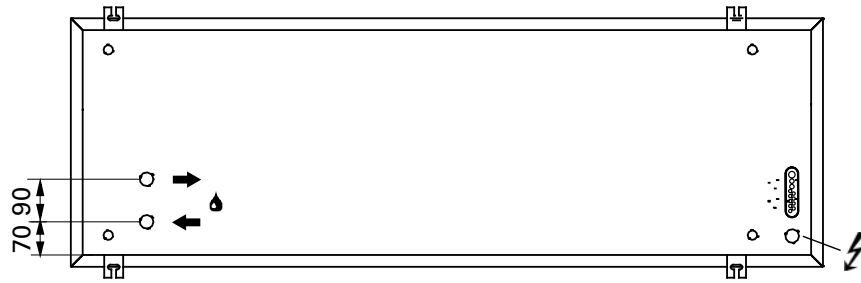
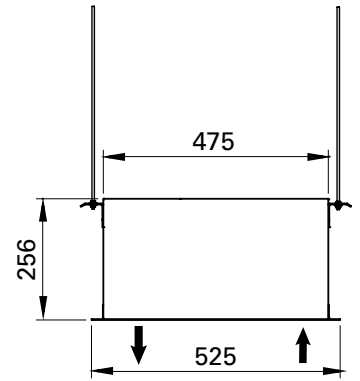
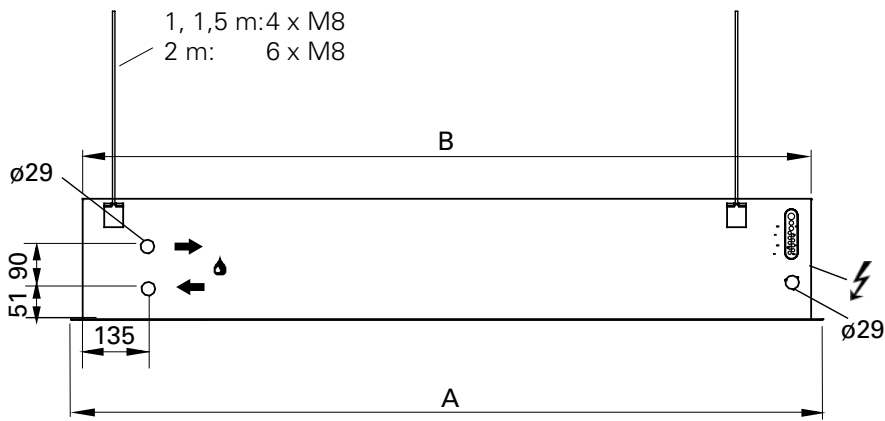

	A [mm]	B [mm]
ARF3210	1078	1028
ARF3215	1588	1538
ARF3220	2078	2028

Arden 3200

Mounting on threaded bars outside the unit / Montage avec tiges filetées à l'extérieur de l'appareil

Front view / Vue de face

ARF3210 / ARF3215

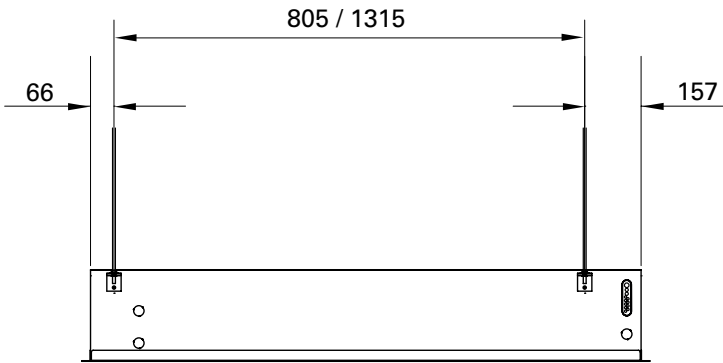

Side view / Vue de côté

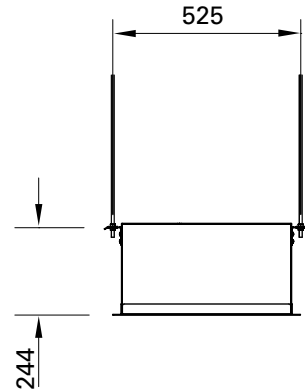

ARF3220

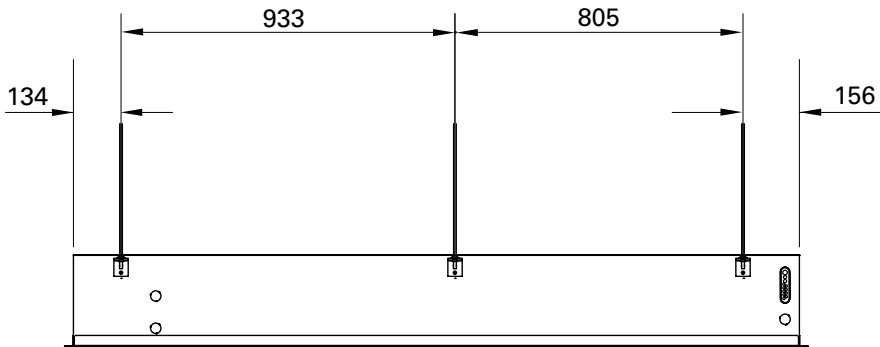

Mounting on threaded bars outside the unit /
Montage avec tiges filetées à l'extérieur de l'appareil

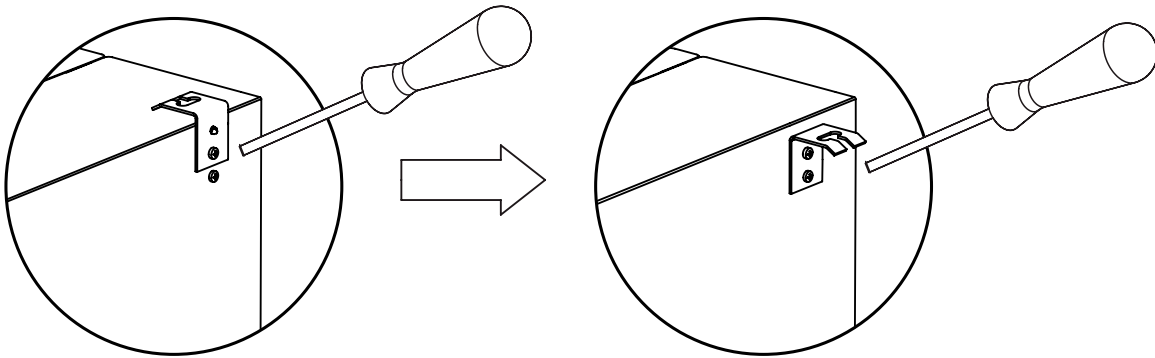

Fig. 1a: Mounting brackets on delivery. / Equerres de montage lors de la livraison.

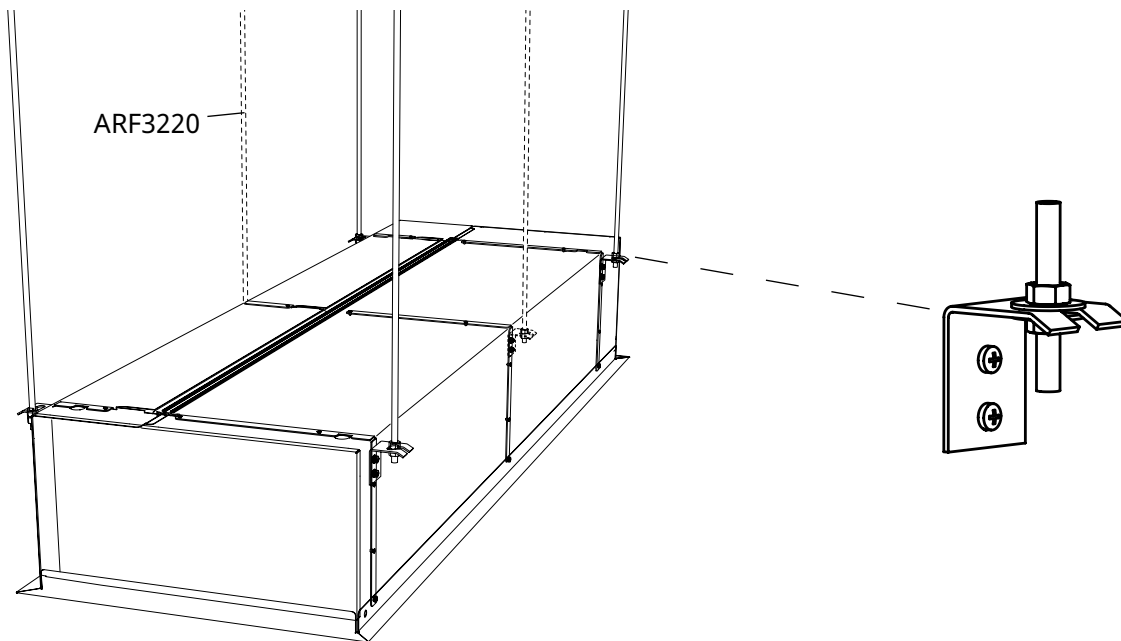
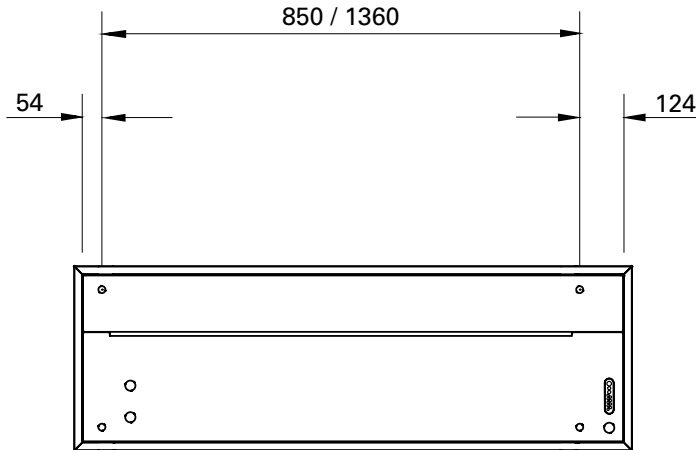

Fig. 1b. Mounting on threaded bars outside the unit. / Montage avec tiges filetées à l'extérieur de l'appareil

Mounting on threaded bars inside the unit /
Montage avec tiges filetées à l'intérieur de l'appareil

Top view / Vue du dessus

ARF3210 / ARF3215



Side view / Vue de côté

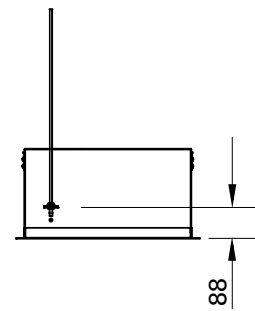

ARF3220

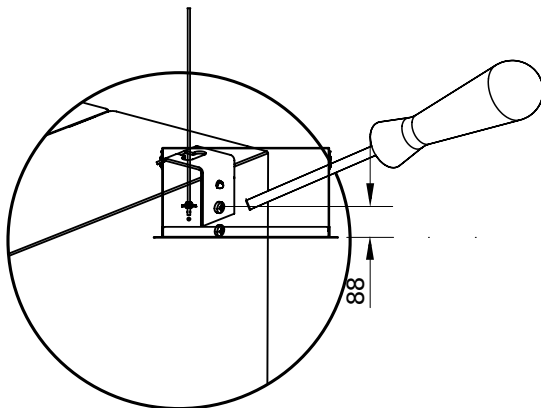
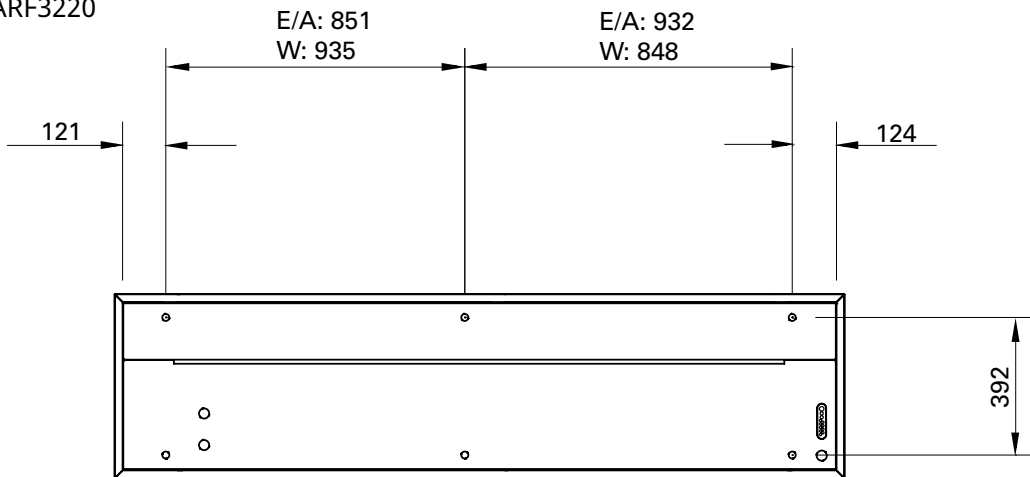

Fig. 2a: Mounting brackets on delivery. / Equerres de montage lors de la livraison.

Mounting on threaded bars inside the unit / Montage avec tiges filetées à l'intérieur de l'appareil

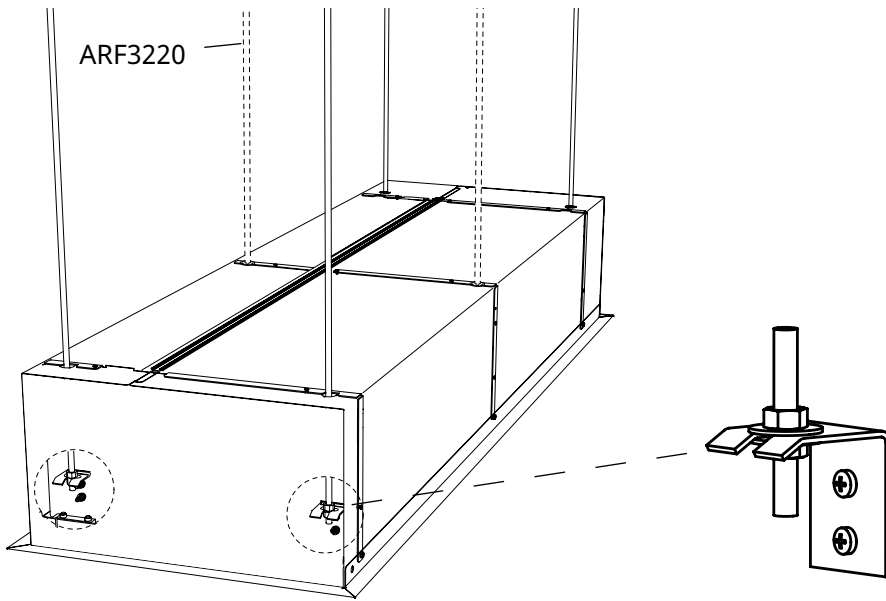

Fig. 2b. Mounting on threaded bars inside the unit. / Montage avec tiges filetées à l'intérieur de l'appareil.

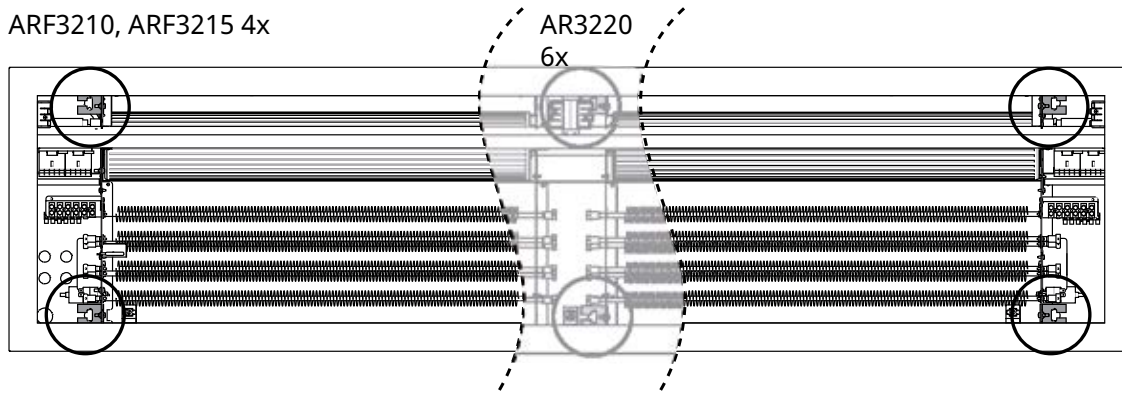

Fig. 2c. Location of the mounting brackets on the inside of the unit. / L'emplacement des équerres de montage à l'intérieur de l'appareil.

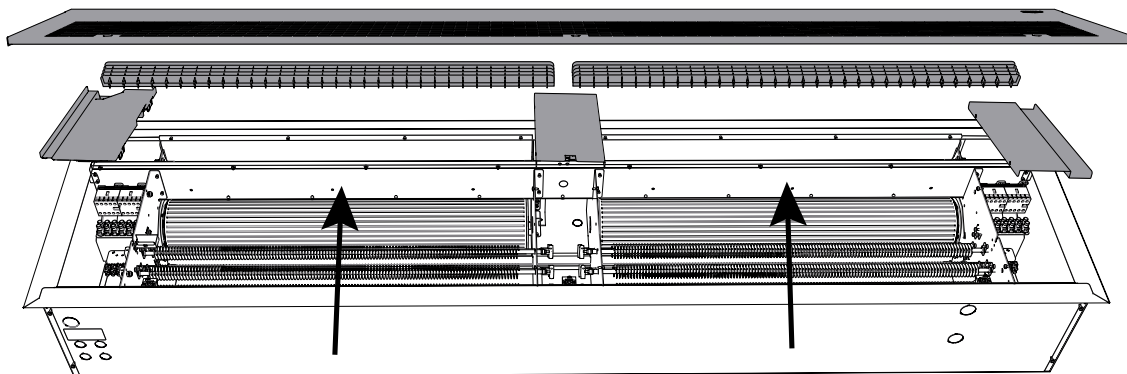

Fig. 2d. In order to mount the brackets, remove the service hatch, outlet grille and covering plates. / Afin de pouvoir monter les équerres, enlever la sous face, la grille de soufflage et les caches.

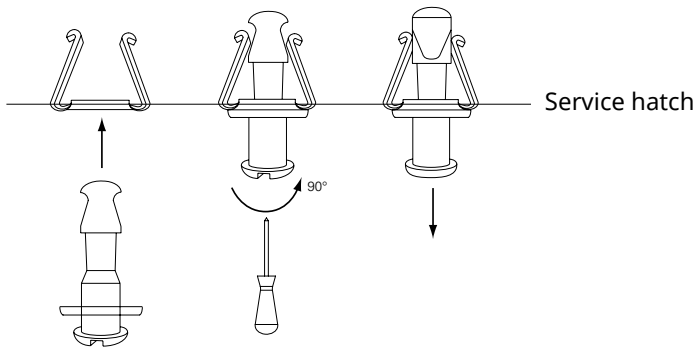

Fig. 3a: Snap fixings / Attaches

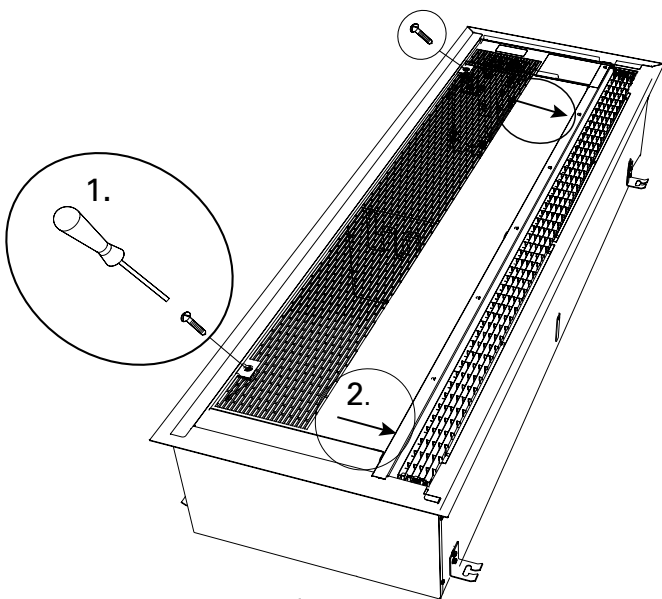

Fig. 3b: Open the unit. / Ouvrir l'appareil.

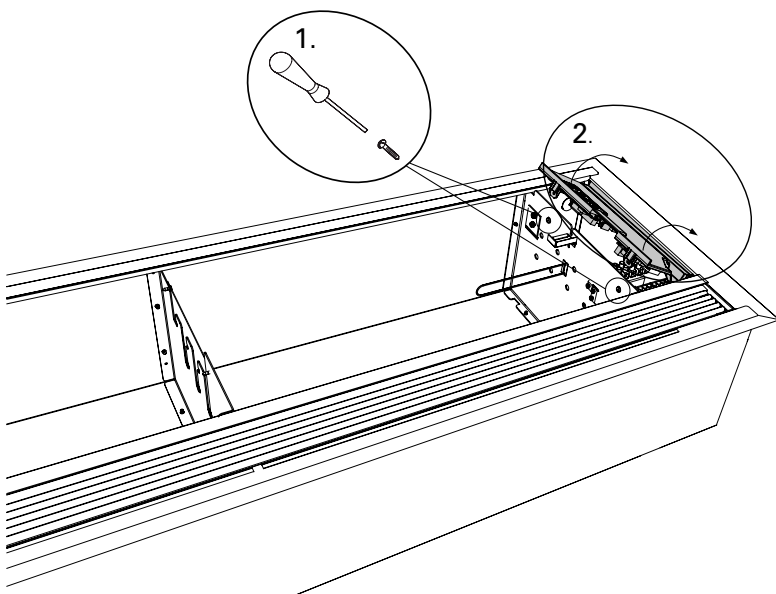

Fig. 4: Terminal box inside unit.

Accessories / Accssoires



PA34TR



PA34CB



PA34VD

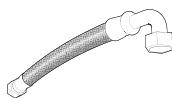

FHDN15

Item number	Type		Consists of	Dimensions
18056	PA34TR15*	ARF3210/3215	4 pcs	L: 1 m
18057	PA34TR20*	ARF3220	6 pcs	L: 1 m
18059	PA34CB15*	ARF3210/3215	4 pcs	
18060	PA34CB20*	ARF3220	6 pcs	
18065	PA34VD15*	ARF3210/3215	4 pcs	
18066	PA34VD20*	ARF3220	6 pcs	
77179	FHDN15	ARF3200W	2 pcs	L: 1 m

*) See separate manual. / Consultez la notice associée.

Valve systems / Vannes

Item number	Type	Connection	Flow range [l/s]
238293	VPFC15LF	DN15	0,012-0,068
238294	VPFC15NF	DN15	0,024-0,13
238295	VPFC20	DN20	0,058-0,32
238296	VPFC25	DN25	0,10-0,60
238297	VPFC32	DN32	0,22-1,03

See separate manual. / Consultez la notice associée.

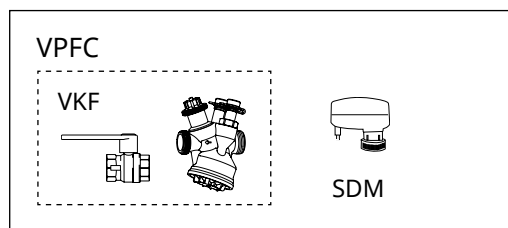

Control systems / Système de régulation

The air curtain must be supplemented with a control system.
Un système de régulation doit être intégré au rideau d'air.

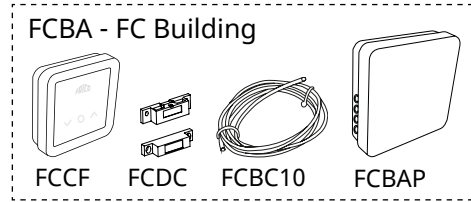
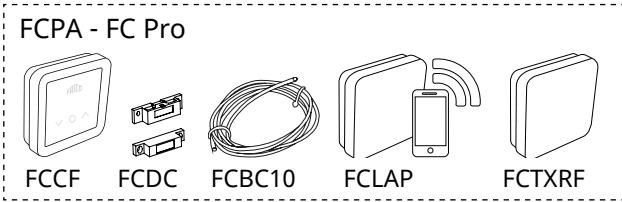
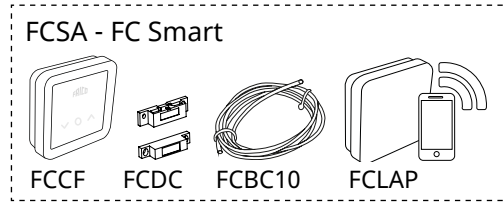
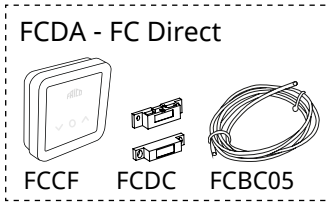

Item number	Type	Name	Dimensions
74684	FCDA	FC Direct	89x89x26 mm (FCCF)
74685	FCSA	FC Smart	89x89x26 mm (FCCF)
74686	FCPA	FC Pro	89x89x26 mm (FCCF)
74687	FCBA	FC Building	89x89x26 mm (FCCF)

Accessories / Accessoires

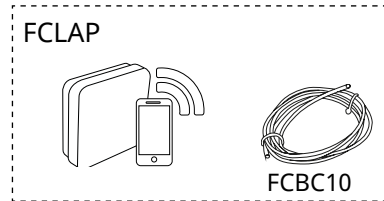
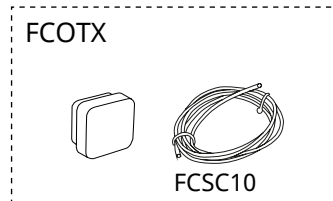
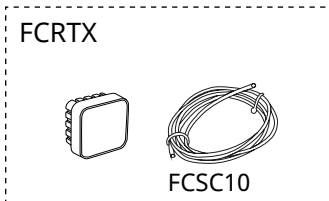

Item number	Type	Dimensions
74694	FCRTX	39x39x23 mm
74695	FCOTX	39x39x23 mm
74699	FCLAP	89x89x26 mm
74702	FCWTA	for water heated units
17495	FCDC	
74718	FCBC05	5 m
74719	FCBC10	10 m
74720	FCBC25	25 m
74721	FCSC10	10 m
74722	FCSC25	25 m
74703	FCTXRF	for FC Smart, FC Pro 89x89x26 mm

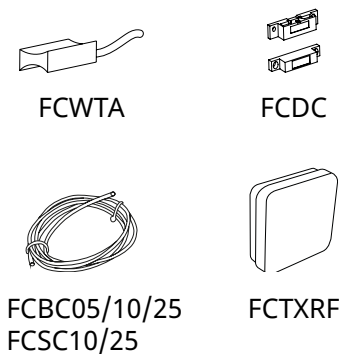

See separate manual for FC. / Consultez la notice de FC.

Technical specifications

Voltage motor: 230V~

⚡ Electrical heat / Chauffage électrique - Arden 3200 E (IP20)

Item number	Type	Output steps [kW]	Airflow*1 [m³/h]	Δt*4 [°C]	Sound power*2 [dB(A)]	Sound pressure*3 [dB(A)]	Motor [W]	Amp. motor [A]	Voltage [V] Amperage [A] (heat)	Weight [kg]
246838	ARF3210E05	1,7/3,3/5	1000/1800	15/8	73	43/57	168	0,7	230V~/21,7 400V3N~/7,2	30
246839	ARF3210E08	3/5/8	1000/1800	24/13	73	43/57	168	0,7	400V3N~/11,6	31
246843	ARF3215E12	3,9/8/12	1600/2900	22/12	73	43/57	283	1,3	400V3N~/17,3	42
246847	ARF3220E16	6/10/16	2100/3900	23/12	73	44/60	366	1,6	400V3N~/23,1	59

💧 Water heat / Chauffage à eau chaude - Arden 3200 W (IP21)

Item number	Type	Output*5 [kW]	Airflow*1 [m³/h]	Δt*4,5 [°C]	Water volume [l]	Sound power*2 [dB(A)]	Sound pressure*3 [dB(A)]	Motor [W]	Amperage motor [A]	Weight [kg]
246840	ARF3210W	8,2	1000/1500	19/16	1,1	69	44/53	133	0,6	30
246844	ARF3215W	14	1700/2600	19/16	1,7	72	48/56	226	1,0	41
246848	ARF3220W	18	2500/3150	18/17	2,3	72	50/56	265	1,2	56



*1) Lowest/highest airflow of totally 3 fan steps.

*2) Sound power (L_{WA}) measurements according to ISO 27327-2: 2014, Installation type E.

*3) Sound pressure (L_{pA}). Conditions: Distance to the unit 5 metres. Directional factor: 2. Equivalent absorption area: 200 m². At lowest/highest airflow.

*4) Δt = temperature rise of passing air at maximum heat output and lowest/highest airflow.

*5) Applicable at water temperature 60/40 °C, air temperature, in +18 °C. See www.frico.net for additional calculations.

*1) Débit d'air mini/maxi de 3 étages de ventilation au total.

*2) Mesures de la puissance acoustique (L_{WA}) selon la norme ISO 27327-2 : 2014, Installation de type E.

*3) Pression acoustique (L_{pA}). Conditions : Distance de l'appareil : 5 mètres. Facteur directionnel : 2. Surface d'absorption : 200 m². Au débit d'air minimal/maximal.

*4) Δt = augmentation de température sous un débit d'air mini / maxi et une puissance maximale.

*5) Valable pour une temp. d'eau de 60/40 °C, temp. d'air d'entrée +18 °C. Consultez www.frico.fr pour des calculs supplémentaires.

Output steps [kW]	= Etages de puissance
Output*4 [kW]	= Puissance
Airflow*1 [m³/h]	= Débit d'air
Sound power*2 [dB(A)]	= Puissance acoustique
Sound pressure*3 [dB(A)]	= Pression acoustique
Voltage motor [V]	= Tension moteur
Amperage motor [A]	= Intensité moteur
Voltage / Amperage heat	= Tension/Intensité chauffage
Water volume [l]	= Volume d'eau
Weight [kg]	= Poids

ARF3210E05

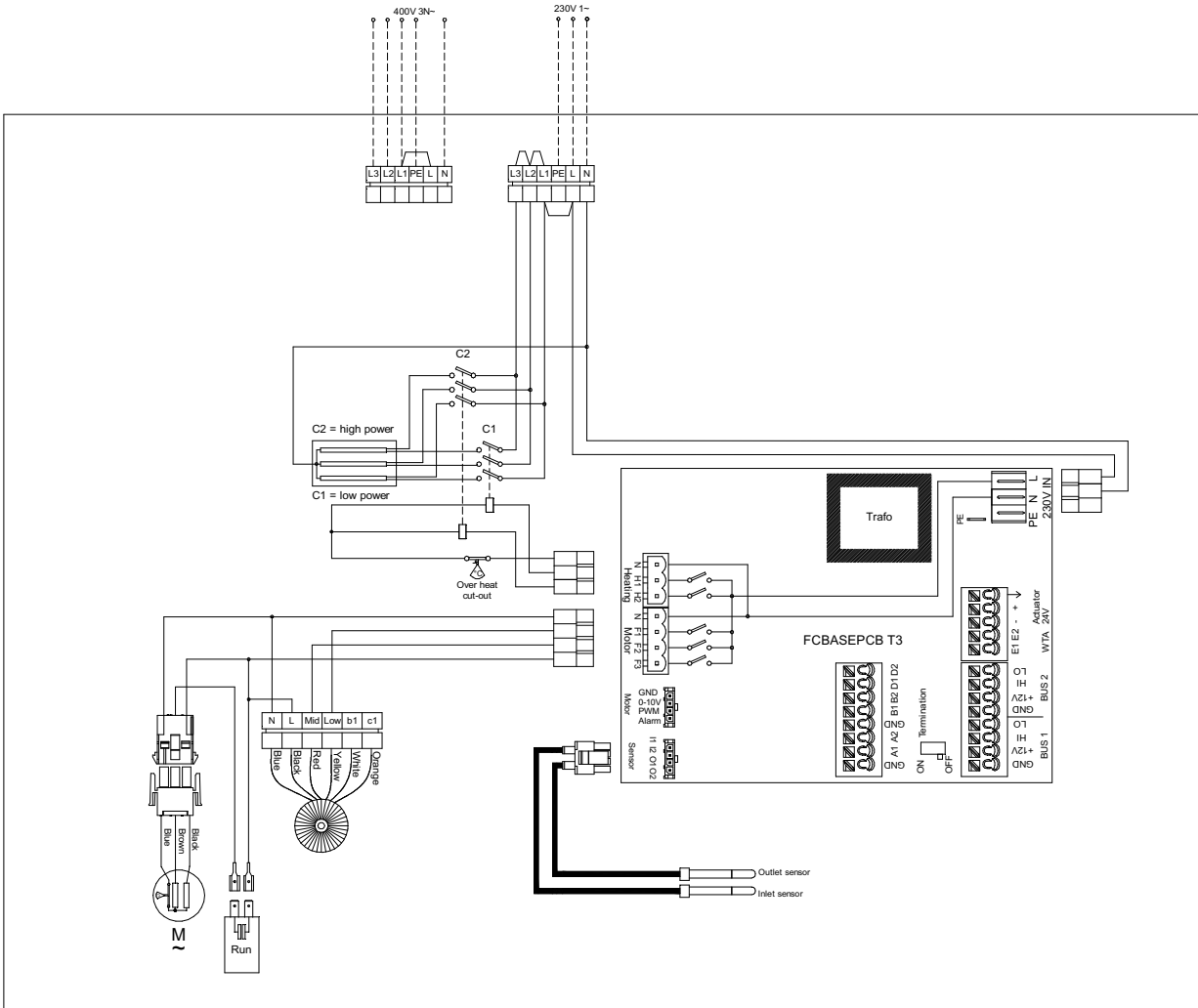

Wiring diagrams for control system in the FC manual.

Arden 3200

ARF3210E08 / ARF3215E12 / ARF3220E16

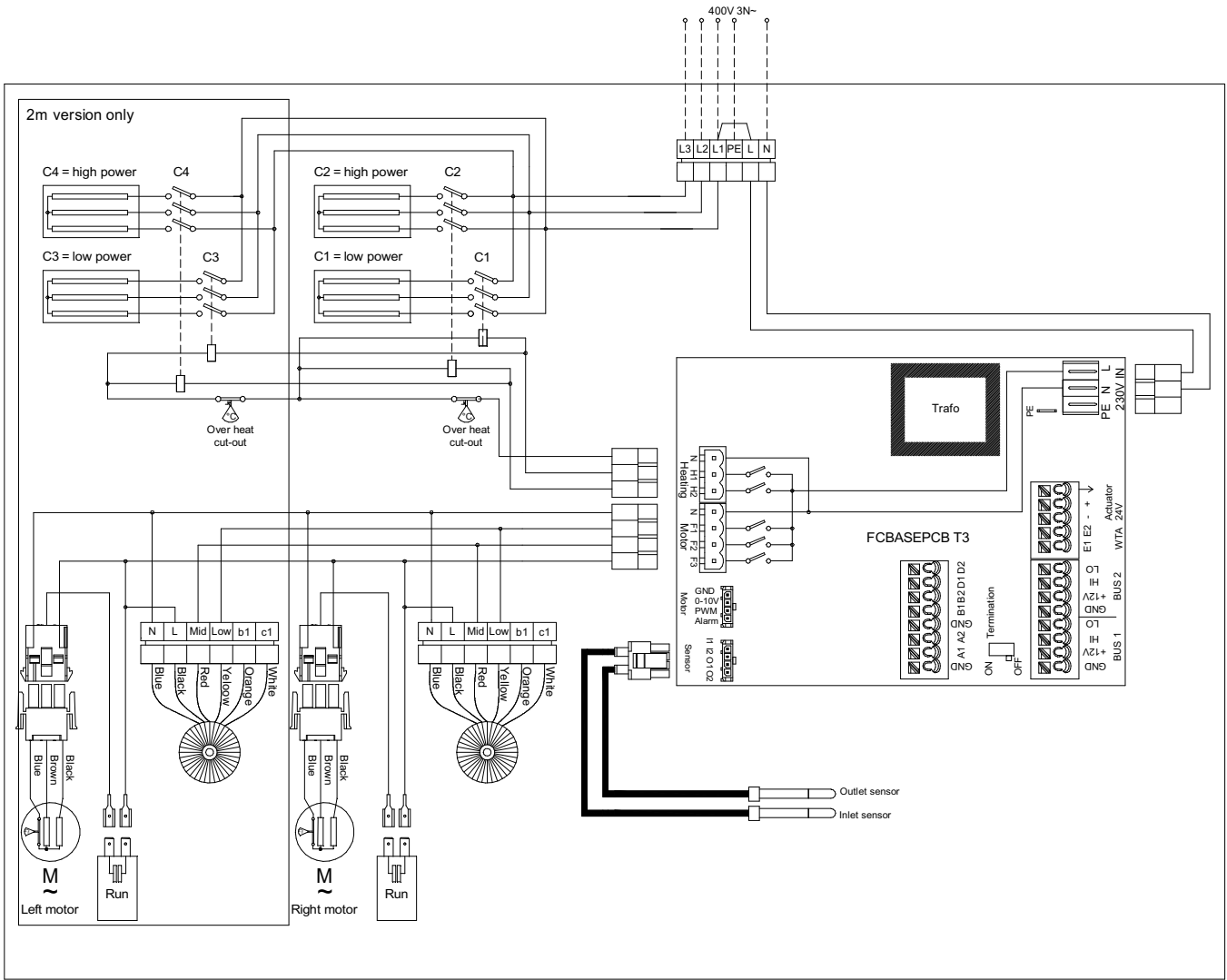

Wiring diagrams for control system in the FC manual.

Installation and operating instructions

General Instructions

Read these instructions carefully prior to installation and use. Keep this manual for future reference.

The product may only be used as set out in the assembly and operating instructions. The guarantee is only valid should the product be used in the manner intended and in accordance with the instructions.

Application area

Arden 3200 is a compact air curtain for recessed mounting. The air curtain is available with electrical heating and with water heating. Recommended installation height for electrically heated units is 3,2 metres and recommended installation height for water heated unit is 2,8 metres.

Protection class for units with electrical heating: IP20. Protection class for units with water heating: IP21.

Operation

Air is drawn in from underneath and blown downwards shielding the door opening and minimizing heat loss. To achieve the optimum curtain effect the unit must extend the full width of the opening.

The grille for directing the outlet air is adjustable and is normally angled outwards to achieve the best protection against incoming air.

The efficiency of the air curtain depends on the air temperature, the pressure differential across the doorway and any wind load.

NOTE! Negative pressure in the building considerably reduces the efficiency of the air curtain. The ventilation should therefore be balanced.

Mounting

The air curtain is installed horizontally with the outlet air grille facing downwards as close to the door as possible, concealed in the false ceiling. The only visible part of the unit is the underside which is level with the ceiling. The service hatch must be accessible, nothing should prevent it being fully opened.

The unit is ready for suspension with threaded bars on its outside. The threaded bars can also be fixed on the inside of the unit e.g. when mounted on a solid suspended ceiling. For the protection of wider doorways, several

units can be mounted in series alongside each other. Minimum distance from outlet to floor for electrically heated units is 1800 mm.

Mounting on threaded bars outside the unit

1. The mounting brackets are fixed to the unit during transport. Loosen these, turn them around and screw into place on the unit according to fig. 1a.
2. Hang on threaded bars (M8) according to fig. 1b (accessory).
3. Adjust the height using the lower nut so that the frame is level with the ceiling. Lock using the upper nut.

Mounting on threaded bars inside the unit

1. The mounting brackets are fixed to the unit during transport. Loosen them and screw them into place inside the unit in the intended holes. In order to mount the brackets, remove the service hatch, outlet grille and covering plates. See pages 6-7.
2. Hang on threaded bars (M8) according to fig. 2b (accessory).
3. Adjust the height using the lower nut so that the frame is level with the ceiling. Lock using the upper nut.

Electrical installation

The installation, which should be preceded by an isolator switch with a contact separation of at least 3 mm, should only be wired by a competent electrician and in accordance with the latest edition of IEE wiring regulations.

The air curtain has an integrated PC board which is connected to the selected external control system FC. FC must be ordered separately. The PC board is accessed via cable glands on the side or the top of the unit. FC is supplied pre-programmed. Communication- and sensor cables are connected to the PC board.

Should more than one air curtain be controlled by a single FC, an additional communication cable FCBC per unit will be required. See manual for FC.

Unit with water heating

The unit is connected via the cable gland on one side of the unit or its top. Pierce the gland with a screwdriver before entering the cable. Control (230V~) should be connected to a terminal block in the terminal box.

Unit with electrical heating

The unit is connected via the cable gland on one side of the unit or its top. Pierce the gland with a screwdriver before entering the cable. Control (230V~) and power supply for heat (400V3~) should be connected to a terminal block in the terminal box.

The cable glands used must meet the protection class requirements. The largest cable diameter for the terminal block is 16 mm².

See wiring diagrams.

Type	Output Voltage		Minimum area* [mm ²]
	[kW]	[V]	
Control	0	230V~	1,5
ARF3210E05	5	230V~/400V3N~	6/1,5
ARF3210E08	8	400V3N~	2,5
ARF3215E12	12	400V3N~	4
ARF3220E16	16	400V3N~	6

*) Dimensioning of external wiring shall comply with applicable regulations and local deviations may occur.

Start-up (E)

When the unit is used for the first time or after a long period of non-use, smoke or an odour may result from dust or dirt which has collected on the element. This is completely normal and disappears after a short time.

Connecting the water coil (W)

The installation must be carried out by an authorised installer.

The water coil has copper tubes with aluminium fins and is suitable for connection to a closed water heating system. The heating coil must not be connected to a mains pressure water system or an open water system.

Note that the unit shall be preceded by a regulating valve, see Frico valve kit.

The connections to the heating coil must be equipped with shut off valves to allow trouble-free removal. Water coil is equipped with a drain and a vent valve. The water coil is connected via connections with dimensions DN15 (1/2"), outside thread, inside the unit. Knockouts are placed on the top and the side of the unit.

NOTE: Care must be taken when connecting the pipes. Use a pipe wrench or a similar tool to grip the air curtain connections to prevent straining of the pipes and subsequent water leakage during connection to the water supply pipe-work.

Adjustment of the air curtain and airflow

The direction and speed of the airflow should be adjusted considering the load on the opening. Pressure forces affect the airstream and force it inwards towards the premises (when the premises are heated and the outdoor air is cold).

The airstream should, therefore, be directed outwards to withstand the load. Generally speaking, the higher the load, the greater the angle required.

Basic setting fan speed

The fan speed when the door is open is set using the control. Note that the airflow direction and the fan speed may need fine adjustment depending on the loading of the door.

Filter (W)

The water coil is protected against dirt and blockage by an internal air filter which covers the coil face.

Service, repairs and maintenance

For all service, repair and maintenance first carry out the following:

1. Disconnect the power supply.
2. The service hatch is opened by loosening the snap fixings located on the bottom of the unit (turn 90°). The hatch must be held when the snap fixings are loosened. See fig. 3a and 3b.
3. After service, repairs and maintenance close the service hatch and make sure that the snap fixings lock securely.

Maintenance

Unit with water heating

The appliance filter should be cleaned regularly to ensure the air curtain effect and heat emission from the device. How often depends on local circumstances. A clogged filter is not a risk, but the appliance function can fail.

1. Disconnect the power supply.
2. The service hatch is opened by loosening the snap fixings located on the bottom of the unit (turn 90°). The hatch must be held when the snap fixings are loosened. See fig. 3a and 3b.
3. Remove the filter and vacuum clean or wash it. If the filter is clogged or damaged, it may need to be changed.

All units

Since fan motors and other components are

maintenance-free, no maintenance other than cleaning is necessary. The level of cleaning can vary depending on local conditions. Undertake cleaning at least twice a year. Inlet and exhaust grilles, impeller and elements can be vacuum cleaned or wiped using a damp cloth. Use a brush when vacuuming to prevent damaging sensitive parts. Avoid the use of strong alkaline or acidic cleaning agents.

Temperature control

Temperature control of FC maintains the exhaust temperature. Should the temperature exceed the preset value, the overheating alarm will activate. For more information see the FC manual.

Overheating

The air curtain unit with electrical heating is equipped with an overheat protection. If it is deployed due to overheating, reset as follows:

1. Disconnect the power supply with the isolator switch.
2. Determine the cause of overheating and rectify the fault.
3. Open the service hatch. Locate the red button next to the terminal box inside the air curtain.
4. Press the red button until a click is heard.
5. Reconnect the unit.

All motors are equipped with an integral thermal safety cut-out. This will operate, stopping the air curtain should the motor temperature rise too high. The cut-out will automatically reset when the motor temperature has returned to within the motor's operating limits.

Replacing heating elements/heating package (E)

1. Mark and disconnect the cables to the heating elements/package
2. Remove the mounting screws securing the heating elements/package in the unit and lift the heating elements/package out.
3. Install the new heating elements/package in reverse order to the above.

Replacing the water coil (W)

1. Shut off the water supply to the unit.
2. Open the vent valve.
3. Open the drain valve.
4. When the water coil is empty, disconnect its connections.

5. Remove the covering plate.
6. Remove the mounting screws securing the coil in the unit and lift out.
7. Move the filter to the new unit.
8. Install the new coil in reverse order to the above.

Draining the water coil (W)

The drain valve is on the underside of the coil on the connector side. It can be accessed via the service hatch.

Replacing motor or impeller

1. Remove frame and side panel.
2. Remove the screw between motor and fan.
3. Disconnect the cables to the motor.
4. Remove the screws securing the motor and lift it out together with the impeller.
5. Install the new motor and/or the new impeller as above in reverse order.

Replacing the PC board

1. The PC board is located in the terminal box.
2. Mark and disconnect the cables to the PC board.
3. Remove the screws securing the board and lift out.
4. Install the new PC board as above in reverse order.

Troubleshooting

If the fans are not running or do not perform properly, check the following:

- The power supply.
- That the intake grille/filter is not dirty.
- That the motor's safety cut-out has not been deployed.
- Functions and settings of the FC control system, see the FC manual.

If there is no heat, check the following:

- Functions and settings of the FC control system, see the FC manual.

For units with electrical heating, also check the following:

- Power supply to electric heater coil; check fuses and circuit-breaker (if any).
- That the overheat protection has not been deployed.

For units with a water coil, also check the following:

- That the water coil is air free.
- That there is sufficient water flow and pressure.
- That incoming water is heated adequately.

If the fault cannot be rectified, please contact a qualified service technician.

Residual current circuit breaker (E)

When the installation is protected by means of a residual current circuit breaker, which trips when the appliance is connected, this may be due to moisture in the heating element. When an appliance containing a heater element has not been used for a long period or stored in a damp environment, moisture can enter the element.

This should not be seen as a fault, but is simply rectified by connecting the appliance to the main supply via a socket without a safety cut-out so that the moisture can be eliminated from the element. The drying time can vary from a few hours to a few days. As a preventive measure, the unit should occasionally be run for a short time when it is not being used for extended periods of time.

Packaging

Packaging materials are chosen with consideration to the environment and are therefore recyclable.

Handling of product at end of working life

This product may contain substances necessary for the functionality of the product but potentially dangerous for the environment. The product should not be disposed of mixed with general household waste but delivered to a designated collection point for environmental recycling. Please contact the local authority for further details of your nearest designated collection point.

Safety

- *For all installations of electrically heated products a residual current circuit breaker 300 mA for fire protection should be used.*
- *Keep the areas around the air intake and exhaust grilles free from possible obstructions!*
- *The unit must not be fully or partially covered as overheating can result in a fire risk!*
- *Lifting equipment must be used to lift the unit.*
- *This appliance can be used by children aged from 8 years and above and persons with reduced physical, sensory or mental capabilities or lack of experience and knowledge if they have been given supervision or instruction concerning use of the appliance in a safe way and understand the hazards involved. Children shall not play with the appliance. Cleaning and user maintenance shall not be made by children without supervision.*
- *Children of less than 3 years should be kept away unless continuously supervised.*
- *Children aged from 3 years and less than 8 years shall only switch on/off the appliance provided that it has been placed or installed in its intended normal operating position and they have been given supervision or instruction concerning use of the appliance in a safe way and understand the hazards involved.*
- *Children aged from 3 years and less than 8 years shall not plug in, regulate and clean the appliance or perform user maintenance.*

CAUTION — Some parts of this product can become very hot and cause burns. Particular attention has to be given where children and vulnerable people are present.



Main office

Frico AB

Industrivägen 41

SE-433 61 Sävedalen

Sweden

Tel: +46 31 336 86 00

mailbox@frico.se

www.frico.net

**For latest updated information and information
about your local contact: www.frico.net.**